

# Microwave measurement of intra bunch charge distributions

M. Dehler,

Paul Scherrer Institut, CH-5232 Villigen PSI, Switzerland

e-mail: Micha.Dehler@psi.ch

## Abstract

A direct way of obtaining intra bunch charge distributions is to measure the amplitude roll off as well as the phase behavior of the spectrum of the single bunch self field. To that effect, a microwave pickup together with a microwave front end has been installed in the storage ring of the Swiss Light Source (SLS). As pickup, button type bpms are used, which have been designed for a broad band behavior in the excess of 30 GHz. Three bpms together with their individual front ends are used in order to sample the beam spectrum at frequencies of 6, 12 and 18 GHz, which compares to the standard spectrum of a 1 mA single bunch extending to approximately 12 GHz (13 ps rms bunch length). The signals are mixed to base band in loco using the multiplied RF frequency as a LO. By shifting the LO phase, simultaneously the amplitude roll off as well as the complex phase of the beam spectrum can be obtained. Where using a resonator as a pickup would smear out the response over several bunches, allowing only the determination of average values, the current setup has a band width of approximately 2 GHz, so that individual bunches in the 500 MHz bunch train can easily be resolved.

## INTRODUCTION

Intra bunch properties like the bunch length or the intra bunch charge distribution is reflected in the spectral composition of the self field of the bunches.

Measuring the bunch length makes use of the following property of Fourier transforms. With  $h(t)$  as an arbitrary distribution and  $H(j\omega)$  its Fourier transform, the following holds for the relation between its  $n$ -th order moment  $m_n$  and the Fourier transform [1]:

$$(-j)^n m_n = \frac{\partial^n H(j\omega)}{\partial \omega^n} \Big|_{\omega=0}$$

An alternative representation uses cumulants,  $H(j\omega)$  is expressed via its cumulants  $k_n$

$$H(j\omega) = \exp(j\omega k_1 - \frac{\omega^2}{2} k_2 - j \frac{\omega^3}{6} k_3 \dots)$$

With  $\log(H(\omega)) = a(\omega) + j\phi(\omega)$ , odd cumulants are solely determined from the phase

$$k_{2n+1} = (-1)^n \frac{\partial^{2n+1} \phi}{\partial \omega^{2n+1}}$$

and even cumulants from:

$$k_{2n} = -(-1)^n \frac{\partial^{2n} a}{\partial \omega^{2n}}$$

Relating these to the properties of the beam,  $k_1$  is the center of gravity of the bunch,  $k_2$  its variance aka square of the rms length,  $k_3$  the unnormalized skewness and  $k_4$  the unnormalized excess of the charge distribution in the bunch.

In comparison to other alternatives, this approach for the measurement makes the minimum amount of assumptions about the bunch, be it the shape of its distribution, be it the presence of single or multi bunch instabilities.

With an theoretical bunch length of 13 ps at a nominal single bunch current of 1 mA, the roll-off of the bunch spectrum happens at around 12 GHz, so that measurements should go up to at least 18 GHz. One cannot hope to have an integral view of the bunch spectrum from DC-18 GHz, so the interesting question is the number of frequencies, one needs to sample in order to be sure to see any feature in the bunch charge distribution. This is given by maximum bunch length, which we estimated to be 36 psec. Due to this length even a pure sinusoidal modulation of the density will give a bump in the bunch spectrum with a width of 4.5 GHz to both sides of the modulation frequency. So including some security factors it was decided to setup measurements at 6, 12 and 18 GHz.

## HARDWARE

The hardware setup consists of three separate channels for processing the signals at the dedicated frequencies. As a signal pickups three special BPMS with two buttons sitting in the 28 mm high chamber of the SLS injection straight are used. For an optimum high frequency response, the BPM electrodes consist just of a 50 Ohms line with an inner conductor of 1 mm diameter leading to the vacuum chamber. Since no traditional button shape is used, the stray capacitance of the electrode of 0.02 pF is negligible and the high frequency behavior purely determined by the geometrical dimensions.

Taking not into account the behavior of the ceramic feed through used, which is only specified up to 18 GHz, the power spectrum as seen in figure 1 shows a strong high pass behavior. Including the Gaussian roll off of a 13 ps bunch length into the calculation gives maximum power at around 23 GHz – with zero bunch length, the peak would sit at around 80 GHz. Interesting values for the use of wide band electronics are the peak powers emitted by the electrodes. With the worst case assumption of no bunch lengthening, a 10 mA/13 ps rms single bunch produces a peak of 4 dBm or 2.2 mW.

As seen in figure 2 the BPM signals pass low pass filters and are fed into hybrids giving sum and difference signals.

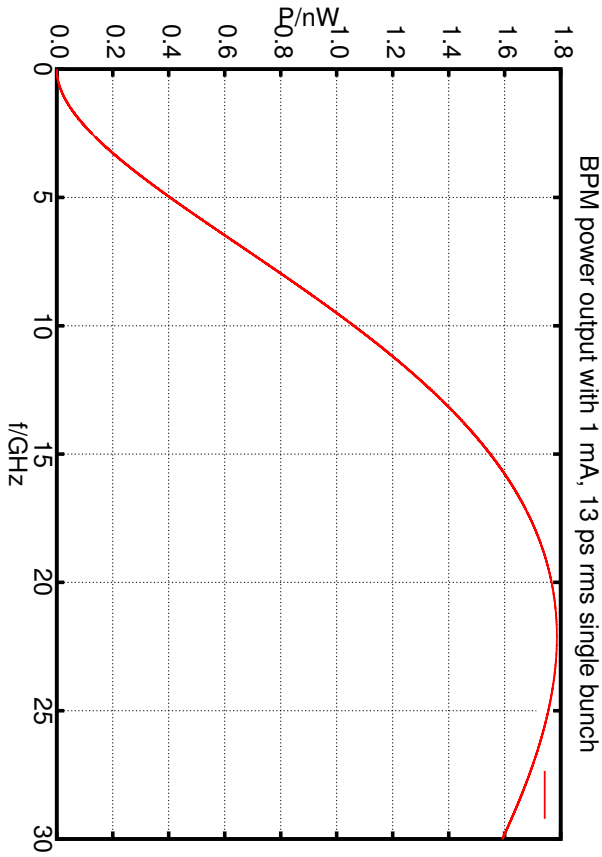

Figure 1: Power spectrum at the output of the two-button BPM assuming a 1 mA single bunch with the theoretical value for the SLS of 13 ps rms.

Subsequent double balanced mixers convert these to base-band with an overall bandwidth at the IF outputs of DC - 2 GHz. In order to be able also to extract the phase informations, the LO signal is obtained by multiplying the storage ring RF of approximately 500 MHz. Thus being phase locked, the LO phase can be shifted via a variable delay line, the DC offset of the IF output as a function of the delay time will give amplitudes as well as phases of the BPM signal. An advantage of this approach compared to e.g. I/Q demodulation is, is that the effects of asymmetries in the mixers as well as cross modulation can be detected and corrected during the measurement.

## BEAM MEASUREMENTS

As yet only the sum signals were used for longitudinal phase space measurements. Figure 3 gives an impression of a typical output signal obtained with a partial filling. The overall slope of the amplitude over the train shows clearly the phase slip caused by beam loading effects. The insert gives the fine detail of the signal allowing a good identification of individual bunches.

While in the long term, a read out of individual bunch signals within the train is planned using a dedicated fast ADC ([3]), these measurements were done in single bunch

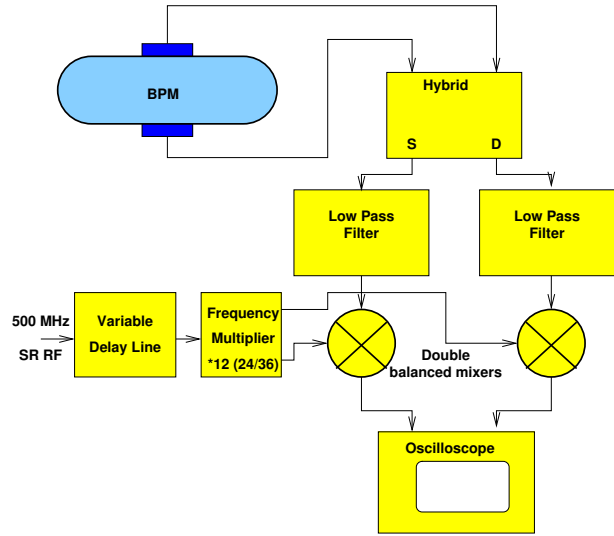

Figure 2: Layout of the electronics front end for one of the channels.

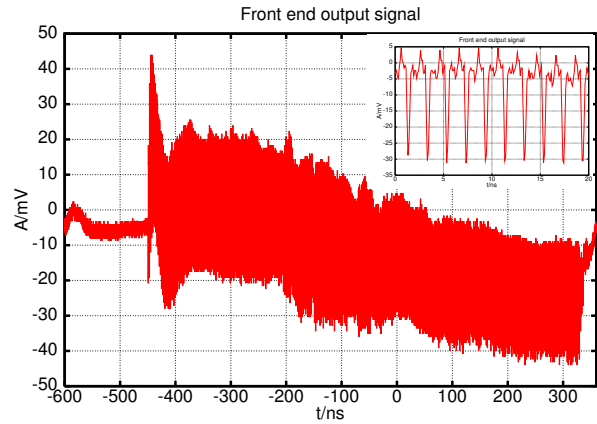

Figure 3: Signal of the 6 GHz channel with a multi bunch (400 out of 480 buckets filled, total current 200 mA)

mode using a GPIB controlled scope for readout. For various delay setting, the signal average in the vicinity of the bunch position was taken, as in figure 4. Two measurement problems can be seen here, the first being irregularities in the setting of the delay line leading to jumps in the 6 GHz output. The second is most pronounced in the 18 GHz output and is caused by harmonics in the frequency multiplier, which lead to spurious effects in the mixers and can be avoided by introducing additional filtering in the multiplier. Nonetheless, doing a Fourier transform of the signal versus delay will identify the correct amplitudes and phases.

With the results obtained, a fit to the higher order moments was done. In order to calibrate the front end for its transmission characteristics, the results for a 0.1 mA bunch current were assumed to be a Dirac type distribution, and subsequent measurements calibrated to that. The fit showed up to be good for the first three moments, the signal distortions discussed above proved to be too strong

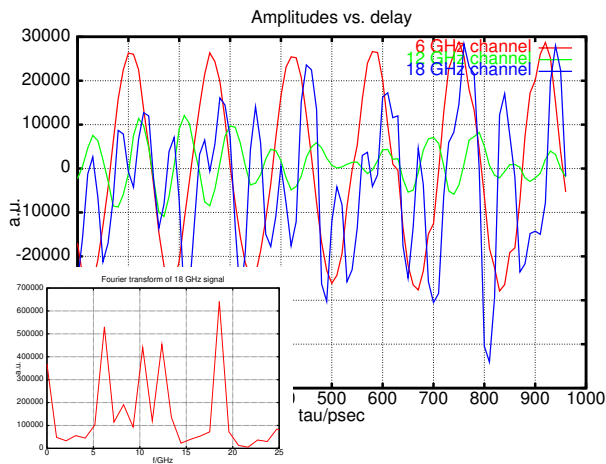

Figure 4: Amplitudes versus delay setting (Bunch current 0.2 mA). In the insert Fourier transform of the 18 GHz output.

to allow a reliable estimate of the fourth order moment (figure 5).

Despite a resolution of the delay line setting of 10 psec and some precision quirks in setting it, a sub picosecond precision corresponding to 0.2 degrees phase in the synchronous phase can be obtained. For the bunch length, the results are distorted due to the multi turn averaging done by the read out scope. As it happens for higher currents, synchrotron oscillations will give an increased value for the averaged bunch length signal. When comparing results to streak camera measurements [2], the otherwise comparable results diverged from 1 mA one, where also synchrotron oscillations were observed with a magnitude explaining the difference. A multiturn signal using the the ADC boards mentioned below should also allow the measurement of synchrotron motion and eliminate this problem. Interesting is also the third order moment describing the symmetry of the space charge distribution, the negative sign indicating an asymmetry in the distribution with a extended bunch tail and a compact bunch head, which can be explained by the asymmetry of the longitudinal wake forces.

## OUTLOOK

The near future will bring further optimization in order to improve the signal integrity of the front end, allow reliable estimates of higher order moments. A promising approach is going to be to take multi bunch data using the ADC boards currently in development at SLS, which allows to obtain intra bunch parameters for the individual bunch in the filling. As yet to be explored are the use of the difference outputs yielding vertical position information, eventually in combination with the side bands of the microwave channels.

## REFERENCES

- [1] A. Papoulis, "Signal Analysis", McGraw-Hill, 1977.
- [2] V. Schlott, personal communication.
- [3] M. Dehler et al, "Capabilities of the SLS Multi Bunch Feedback Electronics", this conference.

